



evoamerica.com



Model# 10-0002

# Evo® Professional Wheeled Cart - Residential



## Gas Circular Flattop Grill

### OUTDOOR

#### Circular Flattop Grill Designed To Create A Social Cooking Space At Home

- 30" (762mm) circular black seasoned steel cooking surface.
- Two circular temperature zones: inner and outer surface.
- Variable temperatures 225°F to 550°F (121°C to 288°C).
- With LP Propane gas 48,000 BTUs.
- With Natural Gas 48,000 BTUs.
- Knobs separately control inner and outer burners.
- Electronic push button ignition.
- LP Propane gas standard, and Natural Gas option.

#### Designed To Setup And Cook Outdoors

- Wheeled positioning on patios or decks.
- Rear handle allows push or pull placement.
- Stainless steel tank sleeve conceals gas tank.
- Quick release removable cook surface and drip pan.

#### Easy Operation, Easy Maintenance, Easy Cleanup

- Cooking techniques: sauté, braise, flattop (plancha) grilling, pan fry, roast, poach, steam, toast.
- Cooking surface is extremely durable and easy to clean.
- Stainless steel burners are protected against spill overs.
- Stainless steel drip pan surrounds cook surface with side mounted spill collection tray.

#### SHORT FORM SPECIFICATIONS:

The Evo Professional Wheeled Cart has a 30" (762mm) diameter black seasoned steel cook surface heated underneath by inner and outer gas tube burners. Surface temperatures range from 225°F to 550°F (121°C to 288°C) from the center to the outside edge. A stainless steel drip pan completely surrounds the underside of the cook surface catching all food debris. The Professional Wheeled Cart is the ideal grill for creating a social cooking space on your patio or deck. Available with either Natural Gas or LP Propane.

## Data

Model	Cook Surface	Dimensions		BTU Rate	Net Weight	Ship Weight
		H	W			
10-0002	30 Inches	37" 940mm	40" 1016mm	NG 48,000 LP 48,000	166 lbs 75 kg	245 lbs 111 kg

Due to ongoing product improvement, specifications are subject to change without notice.





Model# **10-0002** **Evo® Professional Wheeled Cart - Residential**

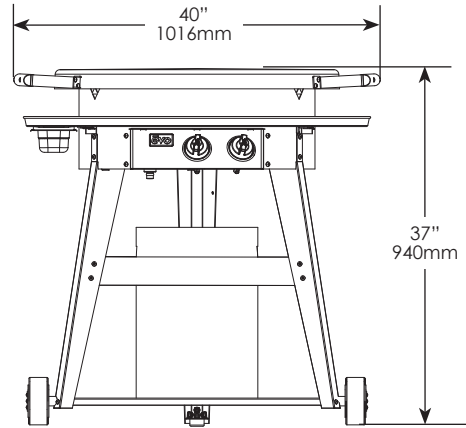
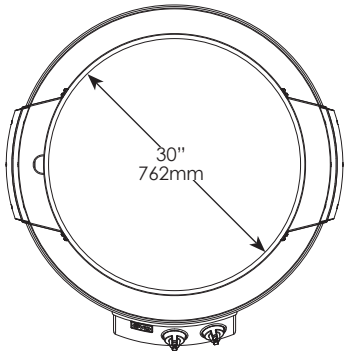

**Optional Accessories**

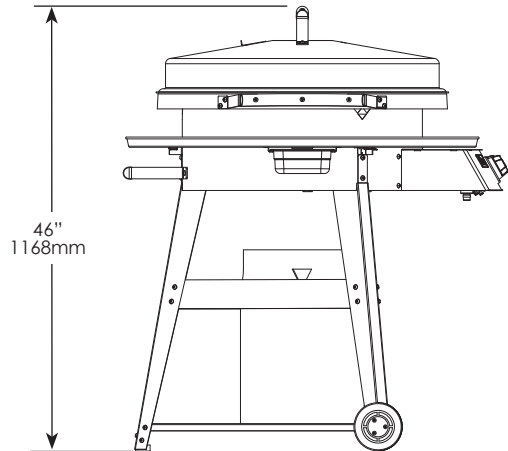

**INSTALLATION REQUIREMENTS**

Cooking surface must be installed level.  
Outdoor installation with minimum 12" (305mm) to adjacent combustible construction extended above the top of the appliance: 12" (305mm) from sides and 12"(305mm) from back.

**NATURAL GAS CONNECTION**

**OPERATING PRESSURE**  
No regulator, connect to an outlet pressure of 7" water column.  
**INLET / SUPPLY CONNECTION**  
1/2" FNPT. 12' Hose with 1/2" FNPT Quick Disconnect Supplied.  
1/2" NPT to 3/8" Flare supplied.  
**BTUs:** 48,000  
**CONNECTION LOCATION**  
Under Front Control Panel.

**LP PROPANE CONNECTION**

**OPERATING PRESSURE**  
Regulator is set for an outlet pressure of 11" water column.  
**INLET / SUPPLY CONNECTION**  
1/2" FNPT Inlet. 5' Hose & Regulator with QCC1 Supplied.  
1/2" NPT to 3/8" Flare supplied.  
**BTUs:** 48,000  
**CONNECTION LOCATION**  
Under Front Control Panel.

**DIMENSIONS**

**MAXIMUM (H X W)**  
46" x 40" with hood (1168mm x 1016mm)  
37" x 40" without hood (940mm x 1016mm)  
**COOK SURFACE**  
30" diameter (762mm)

**WEIGHT**

**NET:** 166 lb EST. (75 kg)  
**SHIP:** 245 lb EST (111 kg)  
**CRATE DIMENSIONS:** 45.5" x 45.5" x 52" (1156mm x 1156mm x 1321mm)

**STANDARD FEATURES**

- 30" circular black seasoned steel cook surface over dual independent manually controlled gas burners.
- Quick release removable cook surface and drip pan.
- Electronic push button ignition.
- Stainless steel lid.

**ACCESSORIES INCLUDED**

- Professional grill surface cleaning kit (3M brand) - Includes handle, cook surface cleaning pad and screen.
- 2 stainless steel spatulas and 1 stainless steel scraper.
- Owner's Manual, Use and Care Instructions & Evo Color Illustrated Cookbook.