



# Evo Professional Commercial Series Presentation Cooking Station Installation Instructions and Owner's Manual



Wheeled Cart Model



Tabletop Model

**For Outdoor Use Only  
Do Not Use Indoors**

Tested &  
Listed By



Portland  
Oregon USA

Certification: ANSI Z83.11-2016 / CSA 1.8-2016

OMNI Report# 141-S-01-5

Part #: Commercial Models: 10-0081-NG, 10-00810-LP, 10-0020-NG, 10-0020-LP

Residential Models: 10-0055-LP, 10-0055-NG

Doc: 1-1-2021 Copyright © 2021

Cleaning Instructions



evoamerica.com

*Pour obtenir un manuel en français, veuillez appeler Evo, America, LLC au 503-626-1802.*

*For a French Language Manual, please call Evo, America, LLC at 503-626-1802.*

## Warnings

### FOR YOUR SAFETY

1. Do not store or use gasoline or other flammable vapors and liquids in the vicinity of this or any other appliance.
2. An LP Tank not connected for use shall not be stored in the vicinity of this or any other appliance.

### FOR YOUR SAFETY

#### If You Smell Gas:

1. Shut off gas to appliance.
2. Extinguish any open flame.
3. Remove grill cooking surface.
4. If odor continues, immediately call your gas supplier or your fire department.

### WARNING

It is the responsibility of the assembler/owner to assemble, install and maintain gas grill. Do not let children operate or play near your grill. Failure to follow these instructions could result in serious personal injury and/or property damage.

### WARNING

This symbol identifies the most important safety messaging in this manual. When you see this symbol, be alert to the possibility of serious bodily injury if the instructions are not followed. Be sure to read and carefully follow all of the messages.

### WARNING

Grill is for outdoor use only. Grill should be operated in a well-ventilated space. Never operate in an enclosed space, garage or building. Your grill is not intended to be installed in or on recreational vehicles and/or boats. Do not install or use grill within 36" of combustible materials from back and sides of grill. Grill shall not be located under unprotected overhead (enclosed carport, garage, porch, patio) made of combustible construction.



Some parts may contain sharp edges as especially noted in this manual. Wear protective gloves as necessary.

## Use Outdoors Only

This appliance shall only be used in an above ground open-air situation with natural ventilation, without stagnant areas, where gas leakage and products of combustion are rapidly dispersed by wind and natural convection.

Any enclosure in which the appliance is used shall comply with one of the following:

- An enclosure with walls on all sides, but at least one permanent opening at ground level and no overhead cover. See Figure 1.
- Within a partial enclosure that includes an overhead cover and no more than two walls. See Figure 2 & 3.
- Within a partial enclosure that includes an overhead cover and more than two, the following shall apply:
  - At least 25% of the total wall area is completely open; and
  - At least 30% of the remaining wall area is open and unrestricted. See Figure 4 & 5.
- In the case of balconies, at least 20% of the total side, back and front areas shall be and remain open and unrestricted.

The following diagrams provide a diagrammatic representation of outdoor areas. Rectangular areas have been used in these figures - the same principles apply to any other shaped area.

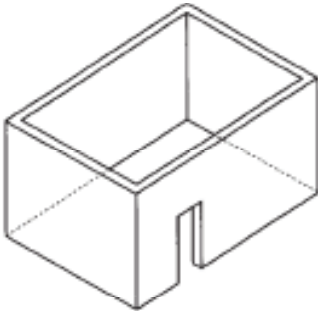

Figure 1 - Enclosure with walls on all sides but no overhead cover.

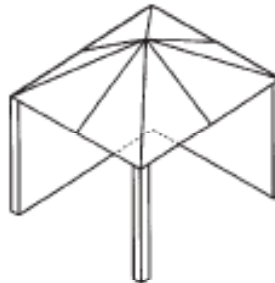

Figure 2 - Partial Enclosure with overhead cover and no more than two walls.

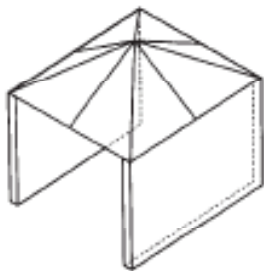
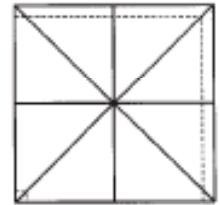

Figure 3 - Partial Enclosure with overhead cover and no more than two walls.

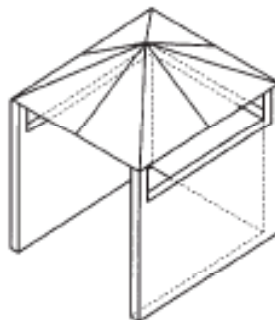
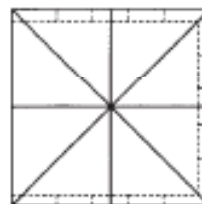
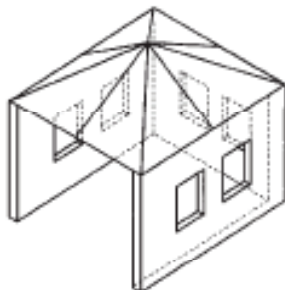
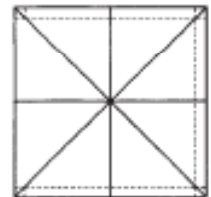

Figure 4 - Open side at least 25% of total wall area. 30% or more in total of the remaining wall area is open and unrestricted



## Commercial Limited Warranty

Evo America, LLC (Evo) warrants to the original commercial foodservice purchaser that the Evo cooking, refrigeration and ventilation equipment shall be free from rust through on all metal surfaces and shall be free from defects in materials and workmanship under normal and reasonable use for One Year from the original date of purchase from Evo. This warranty is for the benefit of the original use purchaser and is non-transferable. Evo promises to replace, at its determination, any product or component that is defective during this initial one year period. Or as a resolution, Evo may at its option repurchase the product at its original purchase price. This is your sole and exclusive remedy. This warranty is subject to the limitations, exclusions and other provisions listed below.

### Limitations Involving Materials and Components:

Warranty does not apply to normal wear and tear, which are expected over the course of ownership. The materials and components listed below are covered according to the following schedule from the original date of purchase from Evo:

- **One Year** – electrical and electronic components [including, but not limited to, electronic displays, overlay and membrane switches, temperature sensors (RTD and K-Value Thermal Couple), hot surface igniters, computers, transformers, heater elements, relays, igniters, ignition controllers, wiring, switches, encoders, outlets and plugs]
- **One Year** – gas components [including, but not limited to, gas regulator, gas hoses, manifold assemblies]
- **One Year** – accessories and repair parts
- **Ninety (90) Days** - refrigeration components [including, but not limited to, compressor, evaporator, pressure control units]

**The original purchase invoice or payment record must be retained and produced upon request if claims are made under this warranty. Warranties are void if the original serial numbers have been removed, altered, or cannot be readily determined.**

**THIS WARRANTY APPLIES ONLY TO PRODUCTS PURCHASED AND LOCATED WITHIN THE UNITED STATES OR CANADA.**

### WHAT IS NOT COVERED BY THIS WARRANTY

1. Conditions and damages resulting from any of the following:
  - a. Improper or inadequate installation, delivery, use, storage or maintenance
  - b. Any repair not authorized in writing by Evo, any modifications, misapplications, or unreasonable use
  - c. Improper setting of any control
  - d. Harsh environmental conditions, including, but not limited to, continual seawater spray, high pressure water, and direct contact with corrosive chemicals and materials
  - e. Excessive or inadequate electrical, gas, or refrigeration supply
  - f. Accidents, natural disasters, acts of God
  - g. Conditions covered by the purchaser's insurance
  - h. Cleaning supplies and filters
2. Labor not pre-authorized by Evo and labor not performed by an authorized Evo service agency or representative
3. Pre-authorized warranty labor performed outside of normal business hours, and at overtime and premium rates
4. The cost of service or a service call to:
  - a. Identify or correct installation errors
  - b. Transport the product or component for service to/from the manufacturer or service center
  - c. Instruct the user of the proper use of the product
5. The cost for any inconvenience, personal injury or property damage due to failure of the product, and cost of damage arising out of the transportation of the product which is covered under different terms with the carrier
6. Natural variations in color and finishes that are inherent to the material and unavoidable (and therefore not defects)

ALL IMPLIED WARRANTIES, INCLUDING THE IMPLIED WARRANTIES OF MERCHANTABILITY, SUITABILITY, QUALITY AND/OR FITNESS FOR A PARTICULAR PURPOSE, ARE LIMITED IN DURATION TO THE EXPRESS WARRANTY PERIODS SPECIFIED ABOVE FOR THE PARTS DESCRIBED THEREIN. EVO AMERICA, LLC MAKES NO OTHER WARRANTY AND WILL NOT BE LIABLE FOR ANY DIRECT OR INDIRECT, CONSEQUENTIAL OR INCIDENTAL DAMAGES.

Some states do not allow limitations on how long an implied warranty lasts, so the above limitation may not apply to you.

Neither Evo manufacturer representatives and dealers, nor the commercial establishment selling this product has any authority to make any warranties or to promise remedies in addition to or inconsistent with those stated above. The maximum liability to Evo America, LLC in any event, shall not exceed the purchase price of the product paid by the original commercial-purchaser. Some states do not allow the exclusion or limitation of incidental or consequential damages, so the above limitations or exclusions may not apply to you. This warranty gives you specific legal rights, and you may also have other rights which vary from state to state.

## Table Of Contents

|  |    |
|--|----|
| Warnings .....                                   | 2  |
| Outdoor Use .....                                | 3  |
| Limited Warranty .....                           | 4  |
| Table Of Contents / Assembly Note .....          | 5  |
| Safety Reminders .....                           | 7  |
| Consumer Service .....                           | 7  |
| Front of Grill .....                             | 8  |
| Top of Grill .....                               | 9  |
| Side of Grill .....                              | 10 |
| Parts List .....                                 | 11 |
| Assembling The Grill .....                       | 12 |
| Legs to Lower Rack .....                         | 12 |
| Wheels to Lower Rack .....                       | 12 |
| Leg Supports To Leg Frame .....                  | 13 |
| Removable Leg Support .....                      | 13 |
| Leg Assembly To Burner Unit .....                | 14 |
| Drip Pan To Burner Unit .....                    | 15 |
| Cooking Surface To Burner Unit .....             | 15 |
| Rear Handle To Burner Unit .....                 | 16 |
| Hood Handle & Hood Support .....                 | 16 |
| Tank Shield .....                                | 16 |
| Removing Leg Support .....                       | 17 |
| Installing LP Tank To Grill .....                | 17 |
| Connecting LP Regulator To Tank .....            | 18 |
| Removal & Storage of LP Tank .....               | 18 |
| Specifications Natural Gas Piping .....          | 19 |
| Installing Natural Gas Connection To Grill ..... | 20 |
| Installing Natural Gas Hose .....                | 20 |
| Checking For Gas Leaks .....                     | 21 |
| Locating the Gas Burners and Orifice Jets .....  | 22 |
| Professional Tabletop Dimensions .....           | 23 |
| Grill Maintenance, Cooking Techniques .....      | 24 |
| Care & Use Guide For Gas Grills .....            | 27 |

## Assembly Note

***Your Evo Flattop Grill is shipped either partially assembled or fully assembled.***

***If you have purchased a partially assembled unit, then you will need to follow the instructions outlined in the table of contents starting from the beginning.***

***If you have purchased an fully assembled unit, then you can skip pages 10, 11, 12, 13 and 15, and move immediately to installing your cooking surface (page 14) and the connection of your LP (propane) or natural gas connection (pages 16-20).***

## Notes

**To Installer or Person Assembling Grill:**

Leave these instructions with consumer.

**To Foodservice Professional**

Keep these instructions for future reference.

**Complete Now For Future Reference**

Serial # \_\_\_\_\_

Date of Purchase \_\_\_\_\_

Place of Purchase \_\_\_\_\_

## Safety Reminders

### SAFETY PRECAUTIONS

- Installation of grill must conform with local codes, or in absence of local codes, with National Fuel Gas Code, NFPA 54 / ANSI Z223.1-latest edition. Handling of LP tanks must conform to NFPA / ANSI 58-latest edition.
- Do not install or use grill within 36" of combustible materials from back and sides of grill. Grill shall not be located under unprotected overhead (enclosed carport, garage, porch, patio) made of combustible construction.

### WARNING

Carefully follow instruction in assembly manual and this booklet for proper assembly and gas leak testing of your grill. Do not use grill until leak checked. If leak is detected at anytime, it must be stopped and corrected before using grill further.

- Grill must not have any obstructions in the venturi-orifice air inlet area.
- Visually inspect hose before each use of grill. If there is excessive abrasion or wear, or if the hose is cut, it must be replaced prior to grill operation.
- Only use valve/hose/regulator that was supplied by Evo with the purchase of your grill.
- Follow lighting and control instructions as described in the Use & Care section of this manual.
- **VERY IMPORTANT:** Never attempt to place any other cooking utensils (skillets, pots, pans) directly on the burners. Only the Evo cooking grill surface is to be placed over the burners. Only use grill with the supplied grill cooking surface. Buildup of non-ignited gas under other utensils is very dangerous.

### WARNING

Do not attempt to put other cooking utensils (skillets, pots, pans) directly on the burners. When grill is not in use, turn off both control knobs and turn tank off.

- Grill cooking area should be kept clear and free from combustible materials, gasoline and other flammable vapors and liquids. Do not obstruct flow of combustion and ventilation air. Keep ventilation openings of LP gas tank enclosure free and clear from debris. Visually check burner flames on regular basis.

- Grill is for outdoor use only. Grill should be operated in a well-ventilated space. Never operate in enclosed space, garage or building. Your grill is not intended to be installed in or on recreational vehicles and/or boats.
- Valve/hose/regulator supplied with grill must be used. Replacement valve/hose/regulator must be those supplied by Evo.
- Carefully follow instructions in assembly manual for attaching regulator to LP tank.
- Purging: Do not release liquid propane (LP) fuel into atmosphere. This is a dangerous practice. If it is necessary to remove fuel from LP gas tank, please call local fire department for assistance.

## Consumer Service

- If you have questions or comments concerning the care and use of your grill, or if you need warranty parts, call 1-866-626-1802 or send a fax to 503-213-5869. To order non-warranty replacement parts or accessories, call 1-800-626-1802 or send a fax to 503-213-5869. **Please know your Grill Serial Number and Date of Purchase before calling.**

## Before Beginning Assembly

- Read all assembly instructions. The installation diagrams are for reference only; they do not contain all information needed to correctly assemble your grill.
- Metal edges can be sharp. Use caution during assembly and use. Wear protective gloves as necessary.
- Lay cardboard on the ground when unpacking. Assemble grill parts on the cardboard to avoid scratching surfaces.
- Necessary tools: Your grill is supplied with a socket and "L" handle, and one 7/16" open-end box wrench. Other tools you will need to supply are a Phillips screwdriver, a hammer and a small wooden block.
- You may fill an LP gas tank purchased from a local supplier prior to assembly. The tank must also have the Safety Cap installed (see diagram) on the tank valve when not in use. Also see your Use & Care Manual.
- If your grill is to be used with a Natural Gas Connection, you must use the Natural Gas Hose Assembly supplied with your Evo grill, or an Evo approved Natural Gas Hose Assembly as shown and described in this manual.



# Know Your Grill From Front To Back

## Front of Grill



1 - Control panel with inner and outer burner control knobs and electronic ignition. Right side of panel contains serial number, certification number and safety instructions. Left-side of panel contains lighting and safety instructions.

2 - Inner burner control knob for controlled temperature across the center portion of grill cooking surface. Inner burner controls cooking area to an 14" radius from center.

3 - Outer burner control knob for controlled temperature across the outer portion of cooking surface. Outer burner controls cooking area 19" radius from center to outer edge.

4 - Three triangular flame viewing portals located in the burner skirt and above each leg position.

5 - Serial number and safety information sticker.

6 - Solid rubber wheels mounted on stainless steel axel and nylon bearings provide durable transport for your grill.

7 - Grill surface is solid plate steel 3/16" thick, 30" in diameter with approx. 650sq. inches of cooking surface.

8 - Handles for removing your grill surface for burner inspection, transportation, or long-term storage.

9 - Drip pan constructed of easy to clean stainless steel for containing food particles.

10 - Burner lighting and ignition instruction sticker located on left side of control panel.

11 - Propane (LP) tank and optional tank shield. Natural gas versions are supplied with quick-disconnect natural gas hose.



# Know Your Grill From Front To Back

## Top of Grill

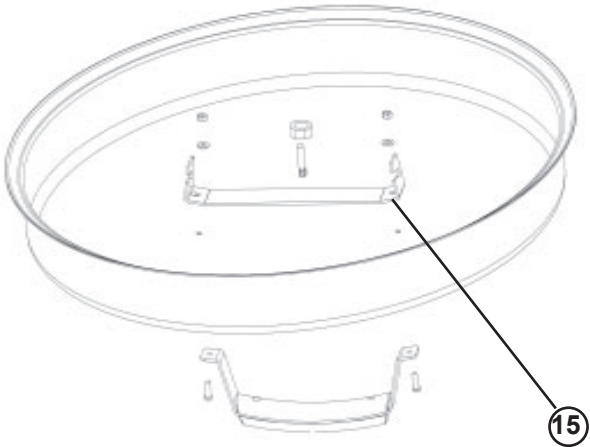

12 - Hood constructed of easy to clean stainless steel for converting your grill into a patio oven, for roasting, smoking, steaming or warming. The hood also protects your cooking surface when not in use.

13 - Vent for exhausting steam or vapors.

14 - Handle for moving your hood onto the cooking surface, and for moving your hood to the resting position.

15 - Hood Hook support for resting hood on backside of drip pan.

# Know Your Grill From Front To Back

## Back of Grill

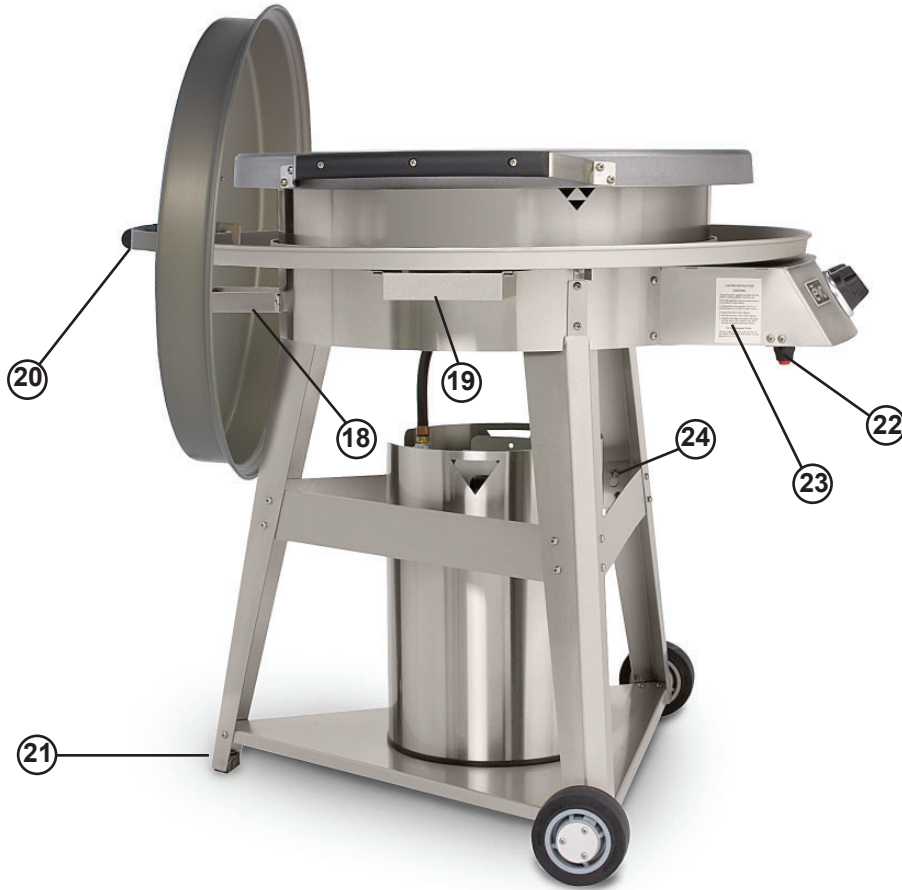

18 - Rear handle for lifting and pushing your grill into position.

19 - Stainless steel waste tray mounted to slide rails under drip pan provides overflow waste removal from drip pan and convenient clean out.

20 - Grill shown with hood resting from drip pan. When hood is not in use, it is recommended to support it from drip pan at the rear location. For complete access to cook surface, remove hood from grill and store separately.

21 - Rear leg rubber foot provides support for positioning grill on deck or patio surfaces.

22 - Electronic ignition is battery operated. The ignitor uses one AAA or AA type battery (installed in ignitor).

23 - Burner lighting and ignition instruction sticker located on left side of control panel.

24 - Removable leg support on right side to access LP tank for refilling. No tools are required to remove leg support. To remove, slide upward and push outward over fasteners.



## WARNING

Replacement of right leg support is necessary after installing LP tank to provide structural stability to the grill.

## Parts List

| Qty                   | Grill Assembly Components                              |
|-----------------------|--|
| 1                     | Right Front Leg  |
| 1                     | Left Front Leg   |
| 1                     | Rear Leg   |
| 2                     | Leg Supports ( LP Only )                               |
| 1                     | Removable Leg Support ( LP Only )                      |
| 3                     | Leg Supports ( Natural Gas Only )                      |
| 1                     | Lower Rack   |
| 1                     | Drip Pan   |
| 1                     | Waste Tray   |
| 1                     | Regulator / Hose Assembly ( LP Only )                  |
| 1                     | Natural Gas Quick-Disconnect Hose ( Natural Gas Only ) |
| <b>Parts Box</b>      |  |
| 1                     | Fastener Package                                       |
| 1                     | Right Wheel Spacer                                     |
| 1                     | Left Wheel Spacer                                      |
| 2                     | Wheel  |
| 2                     | Spanner Bushing  |
| 2                     | Wheel Hub Plate  |
| 1                     | Hood Handle  |
| 1                     | Hood Support   |
| 1                     | Rear Grill Handle                                      |
| 2                     | Hose Clamp and Fasteners ( Natural Gas Only )          |
| 1                     | Electronic Ignitor Battery (AA or AAA)                 |
| <b>Tools Included</b> |  |
| 1                     | Socket and "L" Handle                                  |
| 1                     | 7/16" Open-End Box Wrench                              |
| <b>Tools Required</b> |  |
| 1                     | Phillips Screwdriver                                   |
| 1                     | Hammer   |
| 1                     | Small Block of Wood (Approx. 2" x 4" )                 |
| <b>Literature Bag</b> |  |
| 1                     | Install Instructions & Owners Manual                   |
| 1                     | Use & Care Manual                                      |

You may have extra hardware after completing assembly of your grill. This is normal, as in some cases we have included extra hardware to ensure you have enough.

## Fastener Package Listed in Order of Assembly Group

| Qty  | Key | Legs to Lower Rack   |
|--|-----|--|
| 6  | 10  | 1/4" - 20 x 1/2" Phillips Screw - Stainless Steel  |
| 6  | 11  | 1/4" - 20 Nyloc Nut - Stainless Steel  |
| <b>Wheels to Lower Rack</b>                              |     |  |
| 2  | 20  | 3/8" x 7/8" - Flat Washer - Stainless Steel  |
| 2  | 21  | 3/8" Nyloc Hex Nut - Stainless Steel   |
| 6  | 22  | 8 x 3/8" Phillips Screw - Stainless Steel  |
| <b>Leg Supports to Leg Frame</b>                         |     |  |
| 8  | 30  | 1/4" - 20 x 1/2" Phillips Screw - Stainless Steel.<br>Note: On LP models, 8 screws connect two leg supports. The third removable key-way leg support uses pre-installed hardware.                                    |
| 12   | 30  | 1/4" - 20 x 1/2" Phillips Screw - Stainless Steel.<br>Note: On Natural Gas models, 12 screws are required for connecting all three leg supports to leg frame. Removable leg support not used on Natural Gas models.  |
| 8  | 31  | 1/4" - 20 Nyloc Nut - Stainless Steel.<br>Note: On LP models, 8 nyloc nuts are required for connecting all two leg supports to leg frame. The third (right-most from front of grill) is a removable (keyed) support. |
| 12   | 31  | 1/4" - 20 Nyloc Hex Nut - Stainless Steel.<br>Note: On Natural Gas models, 12 nyloc nuts are required for connecting all three leg supports to leg frame.  |
| <b>Leg Frame Assembly to Burner Unit</b>                 |     |  |
| 6  | 40  | 1/4" - 20 x 1/2" Phillips Screw - Stainless Steel  |
| 6  | 41  | 1/4" - 20 Nyloc Hex Nut - Stainless Steel  |
| <b>Drip Pan to Burner Unit</b>                           |     |  |
| 3  | 50  | 1/4" - 20 x 1/2" Phillips Screw - Stainless Steel  |
| 3  | 51  | 1/4" - 20 Nyloc Hex Nut - Stainless Steel  |
| <b>Rear Handle to Burner Unit</b>                        |     |  |
| 2  | 60  | 1/4" - 20 x 1/2" Phillips Screw - Stainless Steel  |
| 2  | 61  | 1/4" - 20 Nyloc Hex Nut - Stainless Steel  |
| <b>Hood Handle and Hood Support</b>                      |     |  |
| 2  | 70  | 1/4" - 20 x 5/8" Phillips Screw - Stainless Steel  |
| 2  | 71  | 1/4" Lock Washer   |
| 2  | 72  | 1/4" - 20 Hex Nut  |
| <b>Natural Gas Hose to Rear Leg ( Natural Gas Only )</b> |     |  |
| 2  | 100 | 5/8" Stainless Steel Hose Clamps<br>Screw / Nut Combination Included   |

# Assembling The Grill

## Legs to Lower Rack

1. Position bottom of right leg with label marked RIGHT to lower rack and slide over axle.
2. Visually align screw holes and place phillips screw (10) into first mounting hole.
3. Secure to lower rack by first installing Nyloc Hex Nut (11).

**Securely tighten screws by holding screwdriver steady against screw head and using wrench to tighten nyloc hex nut.**

4. Repeat for second mounting hole.
5. Repeat for left leg which is marked with label LEFT.
6. Position bottom of rear leg label marked REAR to lower rack.
7. Visually align screw holes and place phillips screw (10) in mounting hole.
8. Secure by installing Nyloc Hex Nut (11).
9. Repeat for second mounting hole.

**⚠ Some parts may contain sharp edges. Wear protective gloves as necessary.**

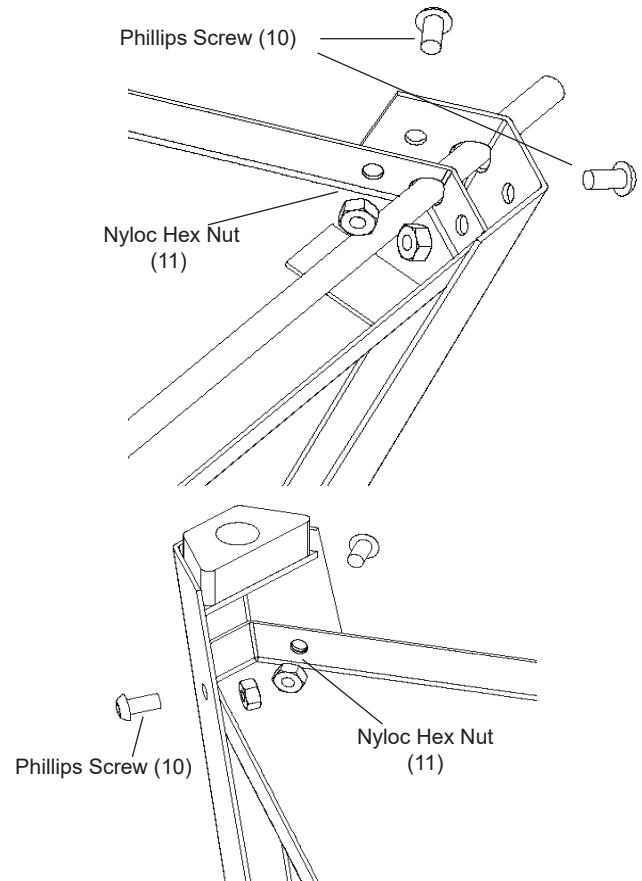

## Wheels to Lower Rack

1. Slide left wheel spacer marked LEFT ( on flat-side of spacer ) over left axle and position cutout to match angle of leg.
2. Slide white nylon spanner bushing over axle and against wheel spacer.
3. Slide wheel over spanner with three hub plate screw holes facing outward.
4. Install washer (20) and nyloc hex nut (21). Tighten nut using socket and L wrench provided in tool kit.
5. Place hub plate over outside of wheel and align with mounting holes in wheel.
6. Install three stainless screws (22) through hub plate and into wheel.
7. Repeat for right wheel installation using spacer marked RIGHT.

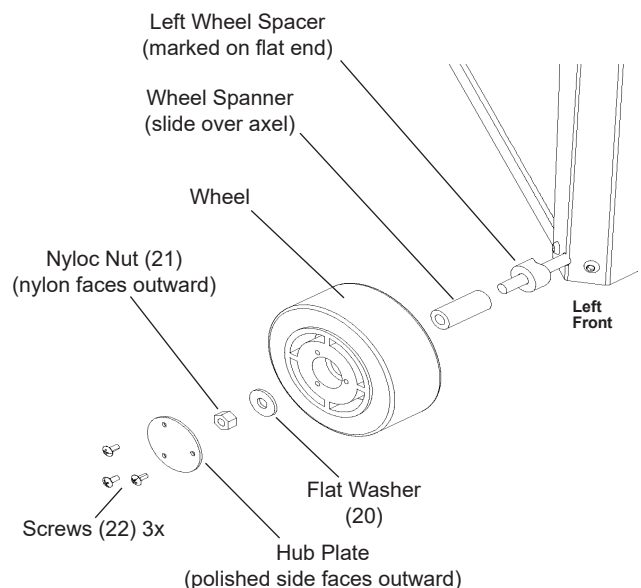

# Assembling The Grill

## Leg Supports To Leg Frame

Propane (LP) models have two leg supports (left-side and front) that are installed using phillips screws and nyloc hex nuts. The third leg support (right-side) is a removable with keyway cutouts that install over pre-installed fasteners (see Removable Leg Support below).

Natural Gas models have three leg supports (left-side, right-side, and front) that are installed using phillips screws and nyloc hex nuts.

1. Position leg support to inside of leg with removable installation label on leg support facing outward. **Be sure angle at each end of leg support matches inside angle of leg.**
2. Visually align screw holes and place phillips screw (30) into first mounting hole with nyloc hex nut securing leg support from behind.
4. Tighten phillips screw to nyloc hex nut and ensure leg support is engaged and leg support is secured against inside of leg.
5. Repeat for all mounting holes of each leg support.

 Some parts may contain sharp edges. Wear protective gloves as necessary.

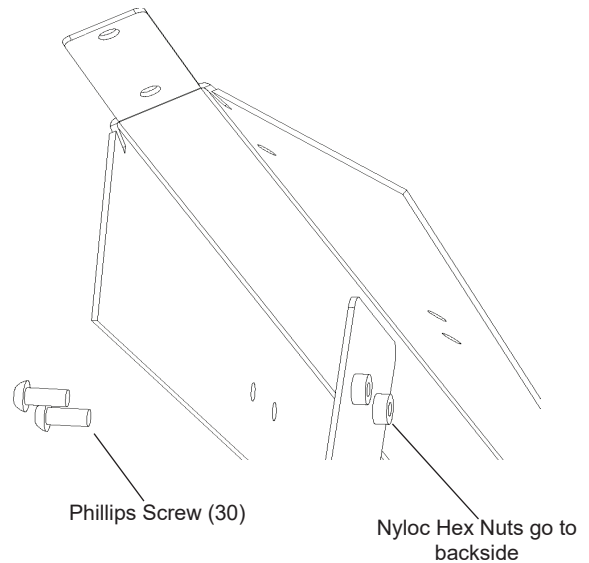

## Removable Leg Support

### Propane (LP) Models Only

1. On LP models, two leg supports are installed to the leg frame using 8 phillips screws and nyloc hex nuts. The third leg support, located on the right-side of the grill, is provided with keyway cutouts which allow easy removal for exchanging the LP tank.
2. The fasteners necessary to engage the removable leg support are pre-installed at the factory and require no adjustment. These fasteners are tensioned with a spring that secures the leg support to the right-front and rear leg.
3. Position removable leg support on inside of leg with the polished factory finish facing outward. Be sure angle at each end of leg support matches inside angle of leg.
5. Visually align keyway holes and leg support over fasteners.
6. Pull inward at each end of the leg support, and then push downward to engage the keyway fasteners.
7. To remove the leg support, reverse the installation process.

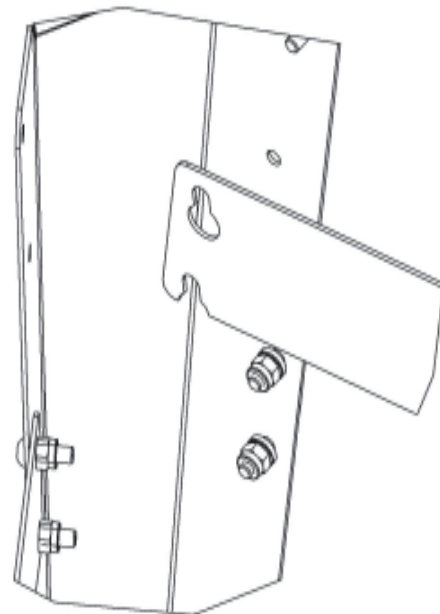

# Assembling Your Evo Grill

## Leg Assembly To Burner Unit



Some parts may contain sharp edges.  
Wear protective gloves as necessary.

1. Stand completed leg assembly in an upright position with the control panel facing forward.
2. Place burner unit over leg assembly with control panel centered between front legs with right and left wheels on each side.
3. Gently lower skirt onto leg assembly making sure the upper tab of each leg rests outside the burner unit skirt.
4. Allow the skirt to gently slide into the vertically angled mounting channels of each leg.
5. Make sure the mounting hole on the skirt is positioned inside the tab of each leg.

**It will be necessary to engage burner unit skirt to leg assembly by using a hammer against a small block of wood and lightly tapping the skirt into the channel of each leg tab.**

**The leg tab will slide over the exposed rivet head located below the first mounting hole of each leg.**

**When the leg tab is properly installed, the rivet head will be under the tab and no longer in view.**

6. Position the burner unit skirt so the mounting hole in each leg tab is visually aligned outside the mounting hole of the skirt.

7. Assemble leg to the burner unit using phillips screw (40), and nyloc hex nut (41).
8. Use 7/16" open-end wrench and phillips screwdriver tools to fasten the legs to burner unit.

**Securely tighten screws by holding screwdriver steady against the screw head while using the wrench to tighten nut.**

9. Repeat for each leg mounting location.

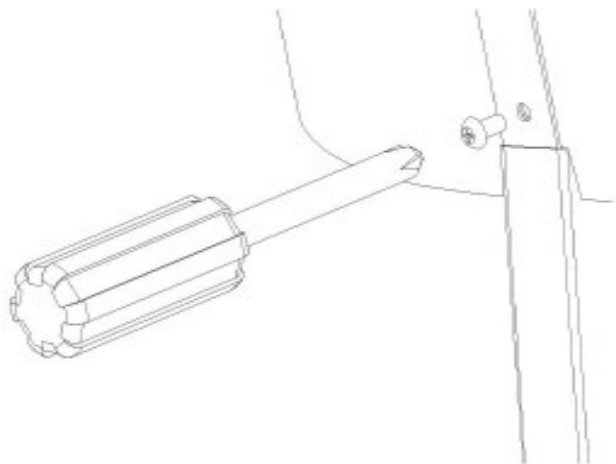
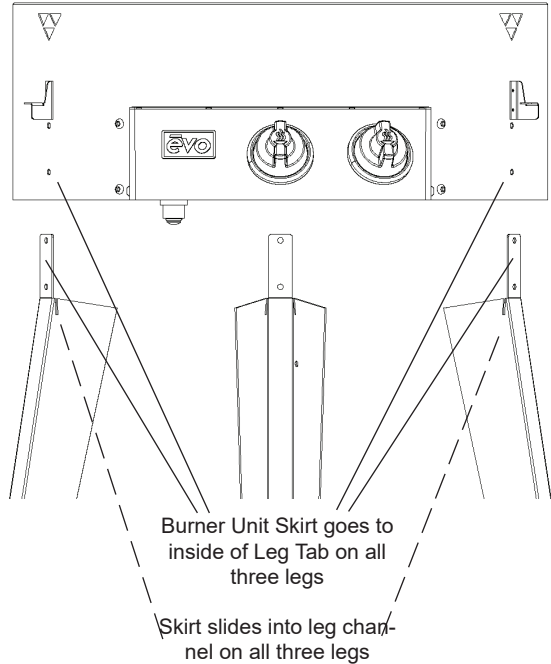

# Assembling Your Evo Grill

## Drip Pan To Burner Unit

1. Lower drip pan over burner skirt with the round clean-out hole of drip pan positioned on the left side of the control panel. The three detent clips and waste container rails must be facing downward.
2. Rest the drip pan on the three support brackets which are riveted to the burner skirt
3. Position the three detent clips just before each support bracket.
4. Grasp the drip pan with both hands across the diameter and firmly rotate the pan to engage each detent clip onto each of the three support brackets.
5. To remove drip pan, reverse the process of installation by firmly rotating the drip pan counter clockwise.

### NOTE:

Because drip pan detent clips are made of a stainless steel spring material, they are rigid when new and it may be necessary to lightly pry each detent clip from its mounting position in order to remove the drip pan. Over time, as the clips are engaged and disengaged, they will become easier to remove and install with a firm rotation of the drip pan.

**Always make sure waste tray is located on left side of grill to allow drip pan detent clips to properly engage the support brackets.**

 Some parts may contain sharp edges. Wear protective gloves as necessary.

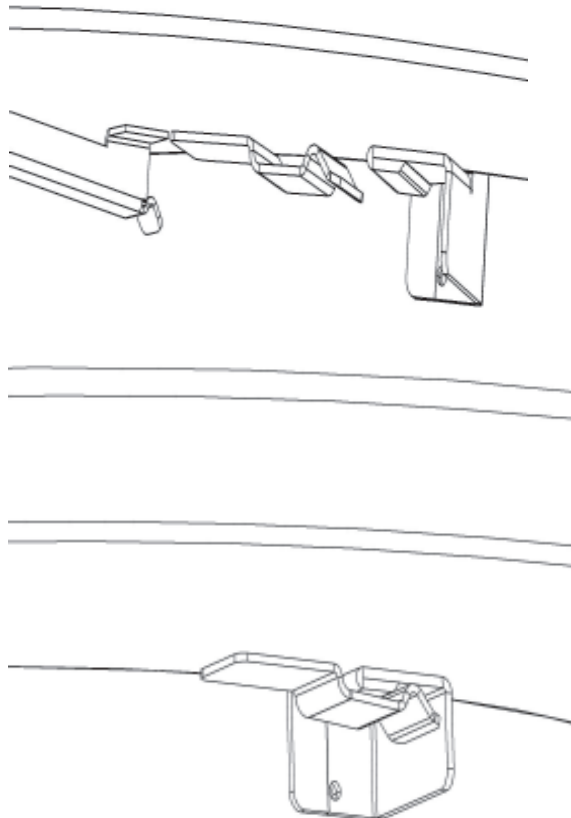

## Cooking Surface To Burner Unit

1. Install cooking surface to burner unit by centering locating tab over burner skirt.
2. Tab Step must be positioned to outside of burner skirt to allow cooking surface to be centered.

**Gently move cooking surface right to left and front to back to locate tabs to skirt.**

## WARNING

Never attempt to install cooking surface when burners are ignited. Failure to follow these instructions could result in serious personal injury and property damage.

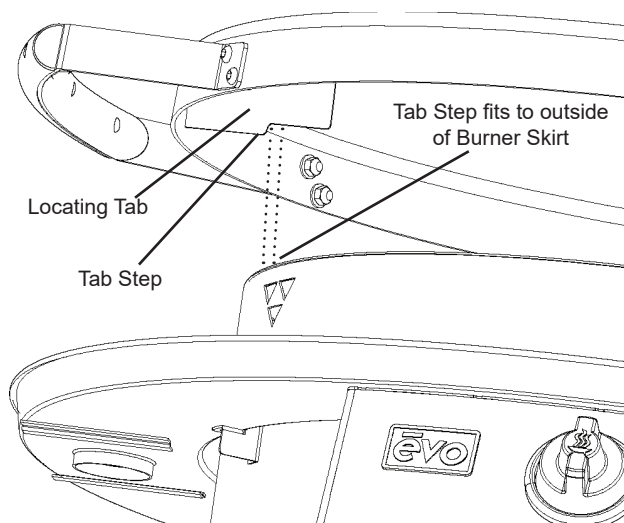

# Assembling Your Grill



Some parts may contain sharp edges.  
Wear protective gloves as necessary.

## Rear Handle To Burner Unit

1. Install Rear Handle to rear of burner unit using two each of phillips screw (60), and nyloc hex nut (61).

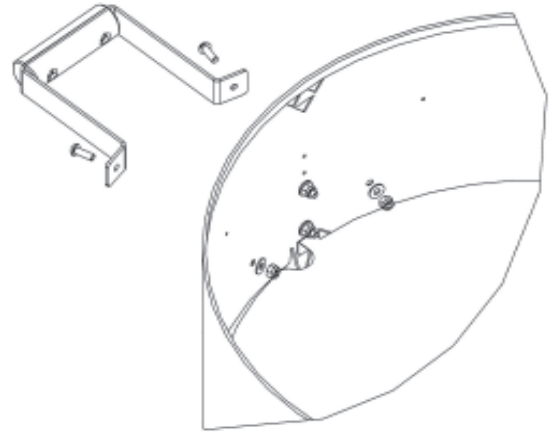

## Hood Handle & Hood Support

1. Install handle to outside of hood by locating phillips screws (70) through the handle and into the hood.
2. From inside hood, simultaneously install the hood support with phillips screw.
3. Secure each phillips screw (70) with two each lock washer (71) and hex nut (72).

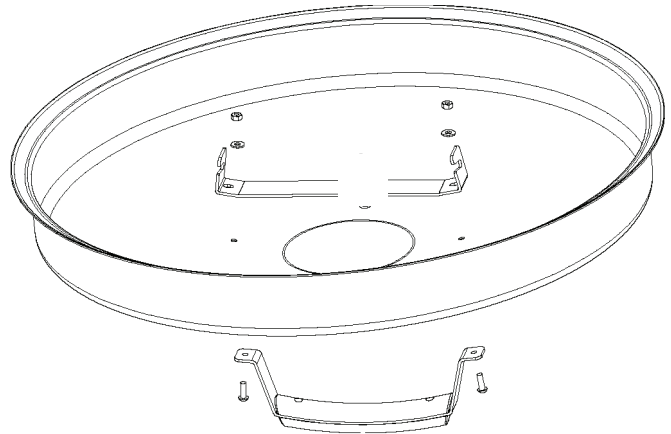

## Tank Shield

**Propane (LP) Models Only**  
**Use Standard 20lb LP Tank**

1. Lift tank shield over LP tank and position with shield cut-out facing the tank valve. When LP tank and tank shield are loaded into grill, the valve should be facing toward the rear leg and inline with the tank shield cutout.

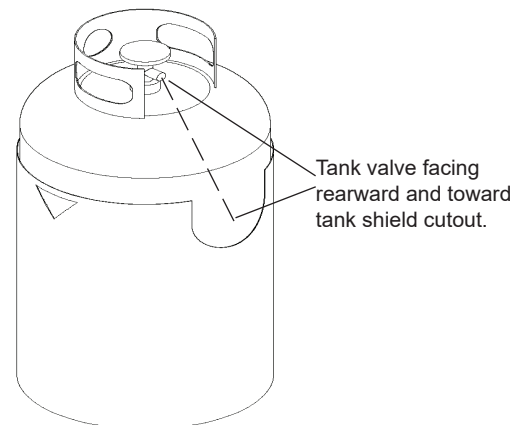



## Installing LP Tank To Grill

### Removing Leg Support

#### Propane (LP) Models Only

1. From right side of grill, grasp removable leg support at each end and lift upward. Once the leg support is disengaged from the keyway fasteners, lift leg support outward.

**The keyway fasteners are tensioned with a spring that secures the removable leg support to the right and rear legs.**

2. Tilt removable leg support to one side and remove from leg frame.
3. Reverse the removal process to install the keyway leg support for exchanging LP tanks.

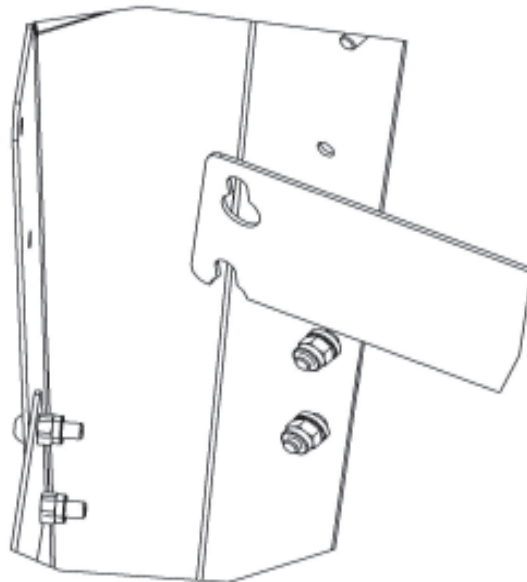

### Installing Tank To Lower Rack

#### Propane (LP) Models Only Use Standard 20lb LP Tank

1. Position tank on ground next to grill with the tank valve outlet facing toward the rear of grill. Lift tank shield over LP tank and position with tank shield cut-out facing the tank valve.
2. Grasp handle of LP tank while simultaneously lifting the tank shield with the tank so the tank rests onto the lower rack and inside the tank ring.
3. Make sure tank valve opening is facing toward the rear of grill and opposite the front control panel.
4. Position LP tank to tank ring on triangular lower rack and make sure bottom foot on LP tank fits securely to tank ring on your grill.

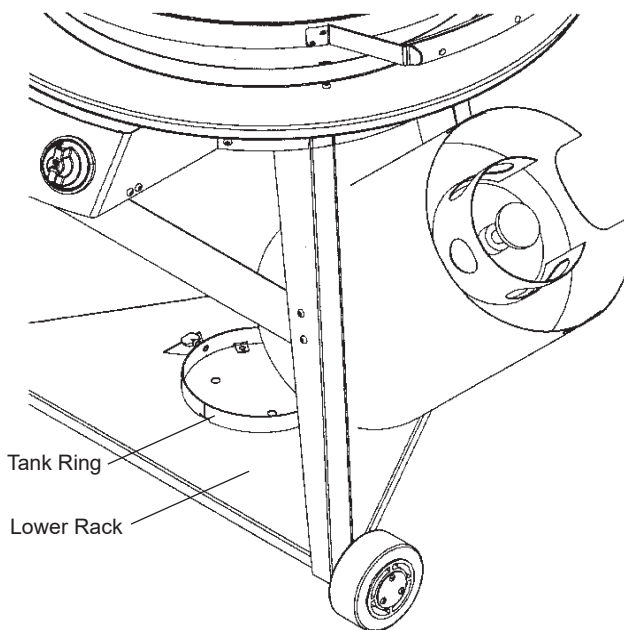

# Installing LP Tank To Grill

## Connecting Regulator To Tank Valve

Refer to the diagram at the right and complete the following steps:

1. Be sure both grill burner valves are in the Off position.
2. Make sure the gas tank valve handwheel is in the closed position. Turn clockwise ( left to right ) to a full stop.
3. Remove the protective cap from the gas tank valve.
4. Hold regulator in one hand and position the plastic coupling nut on the tank valve outlet threads using care to engage the center of the coupling nut to the center of the tank valve outlet. When completing this procedure, take care to not cross-thread the connection.
5. Turn the coupling nut clockwise (left to right) and tighten to a full stop.

**In the connection process, the regulator will seal on the back-check feature in the tank valve resulting in a slight resistance. The connection requires about one-half to three-quarters additional turn to complete the connection. Tighten by hand only - do not use tools. If you cannot make the connection, disconnect the regulator and repeat steps 4 and 5.**

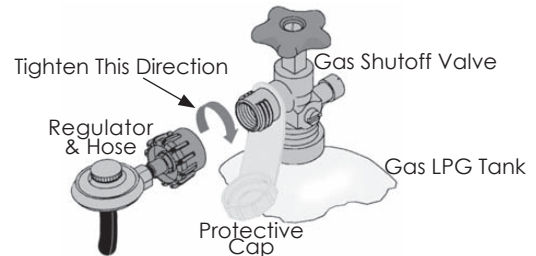

## Removal & Storage Of LP Gas Tank

**Never store LP gas tank indoors. When grill is stored indoors, shut tank valve off and disconnect tank from grill and remove to an outdoor location. Tank must be stored outdoors in well-ventilated area, away from and out of the reach of children.**

1. Remove right-side leg support to gain access to LP tank. For instructions on removing leg support, refer to page 10.
2. Loosen coupling nut located on regulator and tank valve by turning counterclockwise using hands only - do not use tools. Next loosen thumb screws securing tank to lower rack and remove tank. Install safety cap over tank valve coupling.
3. Reinstall leg support.

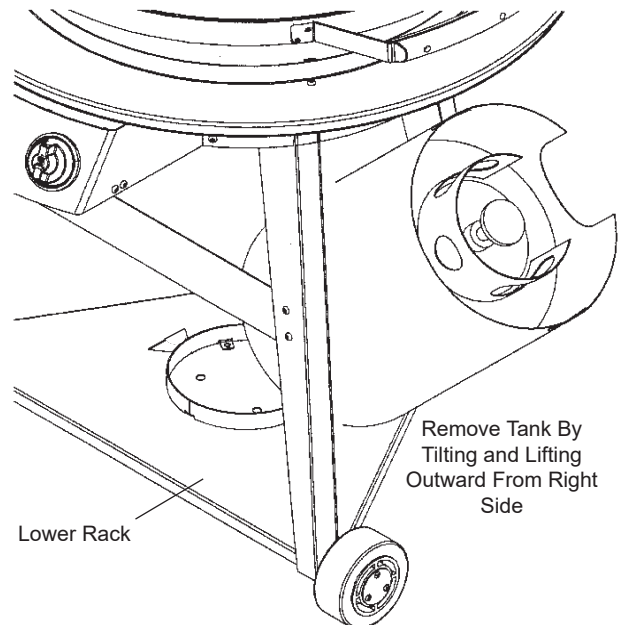

### **WARNING**

NEVER store tank in enclosed area. Safety relief valve on tank could activate releasing gas and causing a fire. All spare tanks must have safety caps installed in tank outlet. Spare tanks should never be stored near the grill.

# Installing Natural Gas Connection To Grill

## General Specifications For Piping

**Note: Contact your local city inspection department for building codes regarding the installation of Natural Gas connection and outdoor gas appliances. In the absence of Local Codes, you must conform to the latest edition of ANSI Z223.1.**

**WE RECOMMEND NATURAL GAS PIPING INSTALLATION BE DONE BY A PROFESSIONAL.**

1. This grill is designed to operate at 7 inches water column pressure ( .2526 psi ).
2. A manual shut-off valve must be installed outdoors, immediately ahead of the quick disconnect.
3. An additional manual shut-off valve indoors should be installed in the branch fuel line in an accessible location near the supply line.
4. The quick disconnect connects to a 3/8 inch NPT thread from the gas source. The quick disconnect fitting is a hand-operated device that automatically shuts off the flow of gas from the source when the grill is disconnected.
5. The quick disconnect fitting can be installed horizontally, or pointing downward. Installing the fitting with the open end pointing upward can result in collecting water and debris.
6. The dust covers ( supplied plastic plugs ) help keep the open ends of the quick disconnect fitting clean while disconnected.
7. Pipe compound should be used which is resistant to the action of natural gas when connections are first made.
8. The outdoor connector must be firmly attached to rigid, permanent foundation.

### Test All Pipe Fitting Connections

All connections and joints must be thoroughly tested for leaks in accordance with Local Codes and all listed procedures in the latest edition of ANSI Z223.1

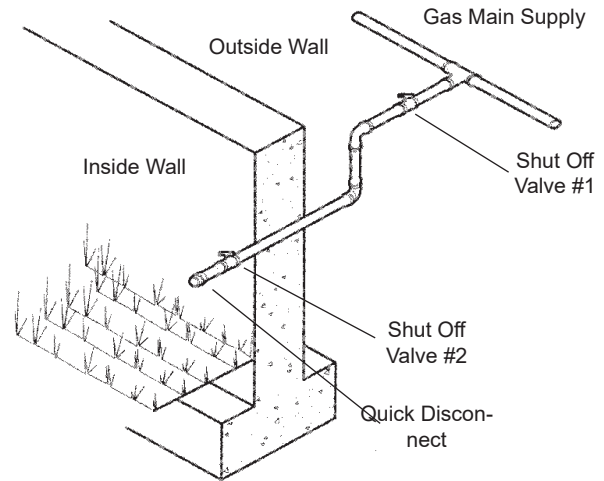

## Gas Line Piping

1. If the length of the line required does not exceed 50 feet, use 5/8 inch O.D. tube. One size larger should be used for lengths greater than 50 feet.
2. Gas piping may be copper tubing, type K or L polyethylene plastic tube, with minimum wall thickness of .062 inch, or standard weight ( schedule 40 ) steel or wrought iron.
3. Copper tubing must be tin-lined if the gas contains more than 0.3 grams of hydrogen sulfide per 100 cubic feet of gas.
4. Plastic tubing is suitable only for outdoor underground use.
5. Gas piping in contact with earth, or any other material which may corrode the piping, must be protected against corrosion in an approved manner.
6. Underground piping must have a minimum of 18 inches ground cover.

## WARNING

Do not route the natural gas hose under a deck or patio.  
The hose must be visible.

## DANGER

Do not use an open flame to check for gas leaks. Be sure there are no sparks or open flames in the area while you check for gas leaks. Flames and sparks will result in a fire or explosion which can cause serious bodily injury or death, and damage to property.

# Installing Natural Gas Connection To Grill

## Installing Natural Gas Hose

Your natural gas grill is shipped with the natural gas quick-disconnect hose preinstalled to the control manifold. To complete assembly, the hose must be routed under the heat shield and through the rear leg.

### DANGER

Natural gas hose must be routed under heat shield. Failure to locate natural gas hose under heat shield will result in a fire or explosion which can cause serious bodily injury or death, and damage to property.

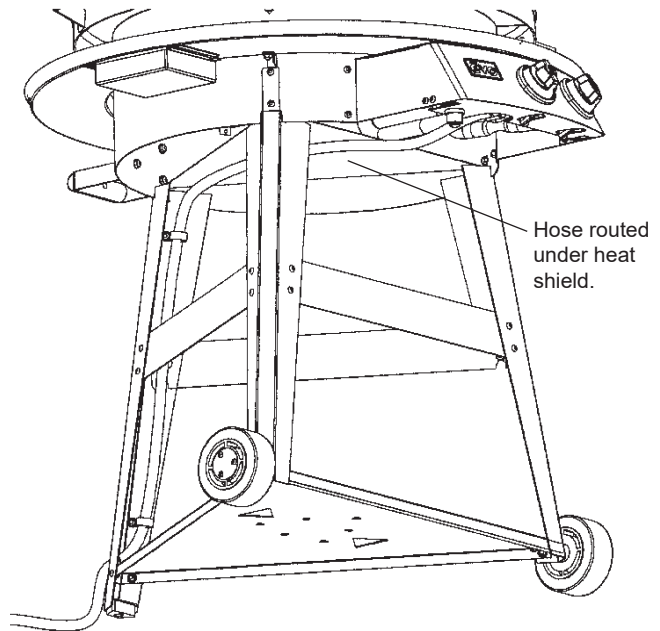

Refer to the diagram at the right and complete the following steps:

1. Remove the natural gas hose from its shipping bag and route hose under the heat shield.

Remove protective cap from the quick-disconnect hose end, and route hose through hole in rear leg.

Reinstall protective cap onto quick-disconnect hose end.

2. Position hose clamp (100) as shown in illustration at two locations on rear leg.
3. Make sure hose runs evenly from the control panel, under heat shield, and outward through rear leg.
4. Using two hose clamps as shown in illustration, secure using fasteners provided with clamps; screw (101), lockwasher (102), and hex nut (103).

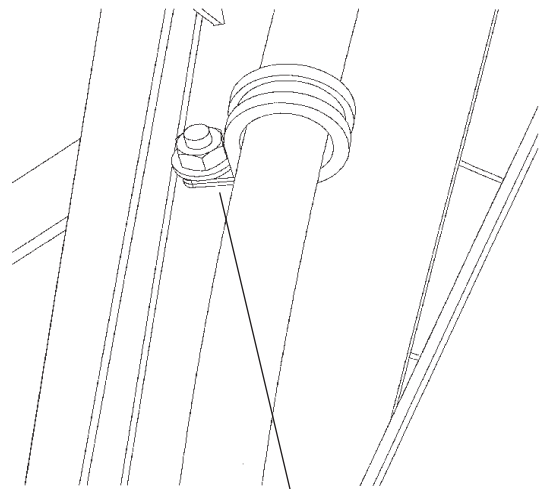

Use Phillips Screw (101), Lockwasher (102), & Hex Nut (103) provided with clamp

# Installing Natural Gas Connection To Grill

## Checking For Gas Leaks

### **DANGER**

Do not use an open flame to check for gas leaks. Be sure that there are no sparks or open flames in the area while you check for gas leaks. Flames and sparks will result in a fire or explosion which can cause serious bodily injury or death and damage to property.

**Note:** All factory-made connections have been thoroughly checked for gas leaks. The burners and ignition system has been flame tested. As a safety precaution, we recommend you recheck all fittings for leaks before using your Evo grill. Shipping and handling may loosen or damage a gas fitting.

**TO PERFORM A LEAK CHECK YOU WILL NEED A SOLUTION OF SOAP AND WATER AND A BRUSH OR RAG TO WET ALL GAS CONNECTIONS.**

1. Slide back the collar of the quick disconnect. Push the male fitting of the hose into the quick disconnect and maintain pressure while releasing the collar.
3. If fitting does not engage and lock, repeat procedure. Gas will not flow unless the quick disconnect is properly engaged.
4. Turn on gas supply and check for leaks by wetting the connections with the soap and water solution and watching for bubbles. If bubbles appear, or if a bubble grows, there is a leak.

**Note:** Since some leak test solutions, including soap and water, may be slightly corrosive, all connections should be rinsed with water after checking for leaks.

**CHECK THE FOLLOWING CONNECTIONS:**

#### 1. HOSE TO MANIFOLD CONNECTION

**WARNING:** If there is a leak where the hose connects to the manifold then retighten the fitting with a wrench and recheck for leaks with soap and water. If leak continues after retightening the fitting, turn off gas. **DO NOT OPERATE GRILL.** Contact your local dealer or Evo Customer Service using the contact information provided with your manual.

#### 2. VALVES TO MANIFOLD CONNECTIONS.

#### 3. HOSE TO QUICK DISCONNECT CONNECTION.

### **WARNING**

You should check for gas leaks every time you disconnect and reconnect a gas fitting.

### **WARNING**

Perform leak checks even if your grill was dealer or store assembled.

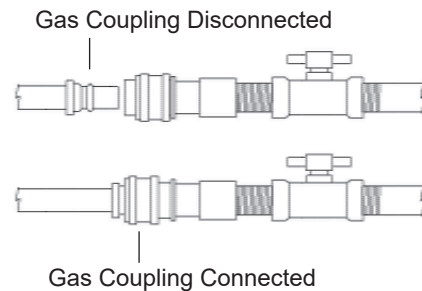

### **WARNING**

Do not ignite burners when leak testing.

## LOCATING THE GAS BURNERS AND ORIFICE JETS

1. The Professional Series Gas Tube Burners are located under the cooking surface and inside the stainless steel burner skirt and are readily visible by removing the cooking surface.. They are arranged with the smaller inner burner located in the center of the burner skirt and the larger outer burner located outside the inner burner.
2. The Gas Burner Orifice Jets for the inner and outer burners are located directly below the circular tube burners and are positioned just inside the Burner Venturi as illustrated below. To remove an orifice, pull the Orifice Retaining Arm away from the orifice and then move the orifice from the venturi.

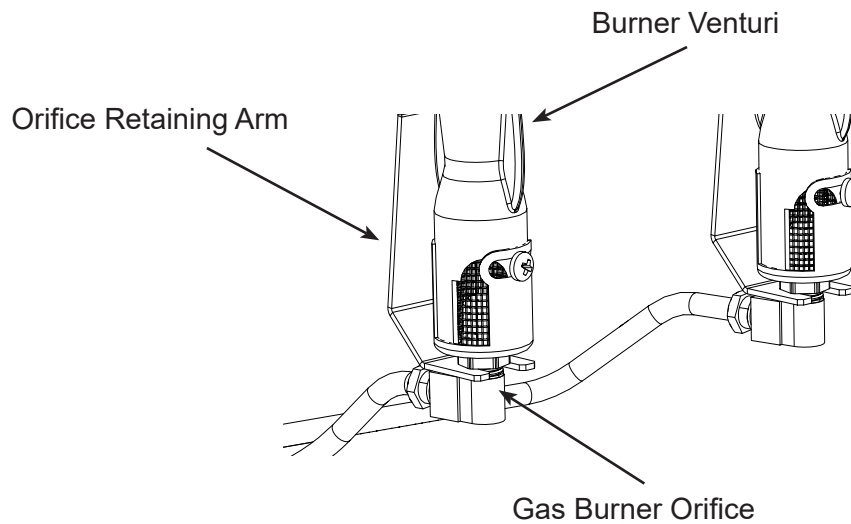

# Professional Series Tabletop Model Dimensions

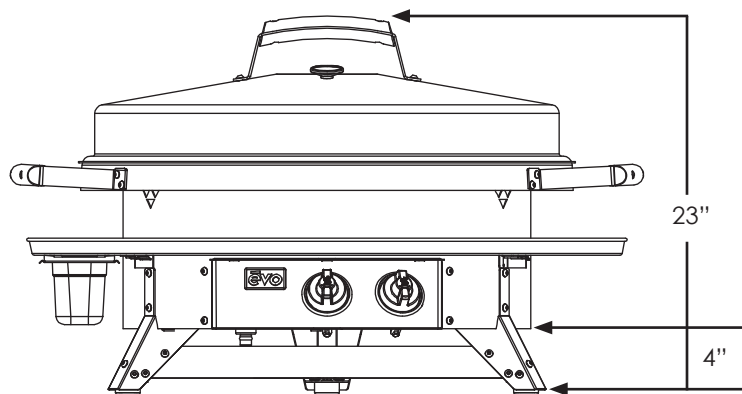
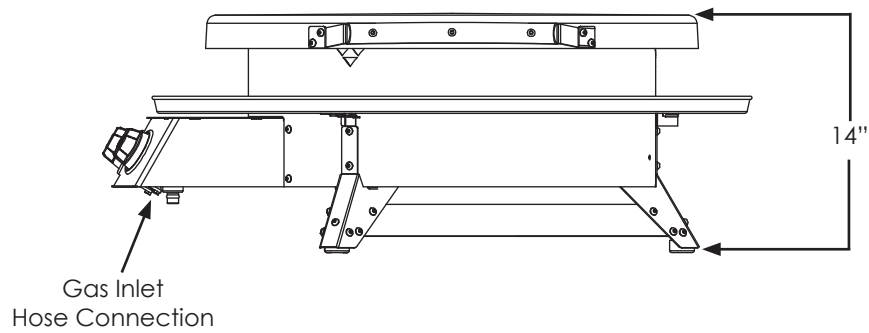
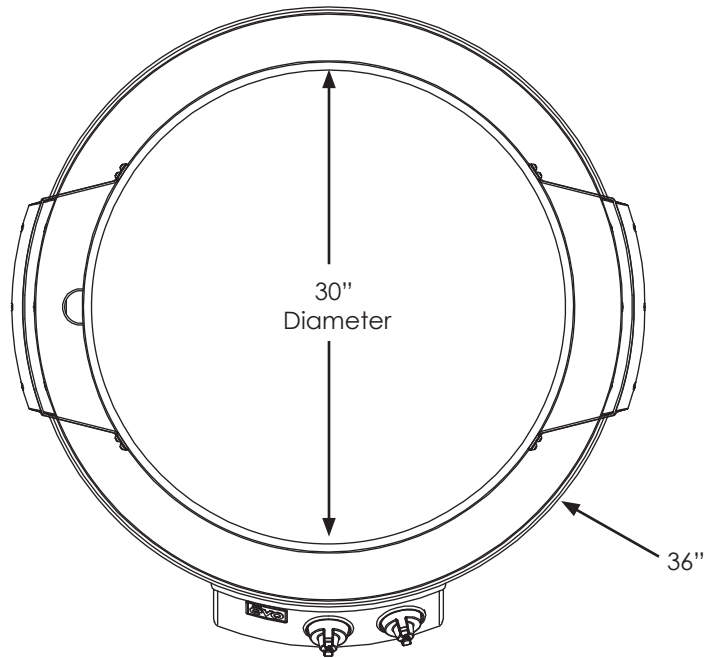

# Grill Maintenance and Cooking Techniques

## Grill Maintenance

Regular cleaning and care for your Evo flat-top cooking surface will keep your grill looking and functioning it's best.

Caring for Evo's cook surface is much like maintaining cast iron cookware. When the surface requires cleaning, there are a few basic cleaning techniques to use. For quick and routine cleaning between preparations, a metal spatula works for removing the majority of surface debris. For tougher areas or where sugars glaze the cook surface, pour a small amount of warm water on the soiled surface while the grill is warm and scrape the debris away with the spatula. It is also possible to use a wire brush to remove sugars or other debris that glaze the cook surface. Heat the cook-surface to a high temperature and allow the sticky debris to become brittle. Once the debris is brittle, use the wire brush to brush it away. After brushing you will want to oil the cook-surface again before cooking. For griddle cooking you will want the cook-surface to be completely free of any debris that might otherwise discolor or impart unwanted flavors.

For griddle cooking you should condition the cook surface with the grill cleaning kit supplied with your Evo grill. The grill cleaning kit contains a professional 3M brand grill screen handle, grill screens, and grill polishing pad. Use the polishing pad after the grill screen to achieve an ultra clean, smooth cooking surface for the most delicate foods and applications.

To use a grill screen: Place one gray polishing pad between the grill handle base and one grill screen, so the grill screen makes direct contact with the cooking surface. Pour a small amount of vegetable oil on the cook surface and scrub the surface in a circular motion. The gray polishing pad allows excess oil to be absorbed and also helps prevent the screen from getting clogged with debris. When finished scrubbing, wipe the surface down with a paper towel or cotton terrycloth.

The drip pan located just below the cook surface is designed to catch food debris and drippings from the cook surface. We recommend cleaning the drip pan after your grill has cooled to prevent the possibility of touching hot adjunct surfaces. The drip pan is easy to wipe out with soap and water using a kitchen sponge. For added convenience, a removable stainless waste try is mounted under the left hand side of the drip pan and can be easily washed by hand or in a dishwasher. Be sure to empty the waste tray after every use.

All of the stainless steel components on your grill can be easily polished using a stainless steel cleaner/polish. The product we recommend is called "Sheila Shine" and is a commercial product normally available from industrial restaurant supply houses. Sheila Shine can be purchased from the Evo web site along with replacement grill polishing pads at [www.evoamerica.com](http://www.evoamerica.com).

## Cooking Techniques

### Stove Top Cooking and Heat Zones

You can use Evo's cook surface similar to the burners on your kitchen stove top. Adjust Evo's burners to control the temperatures of the cook surface "heat zones." Evo's circular grill top is divided into two distinct zones. The center control panel knob controls the "inner heat zone," which is also the inner circle of the cook surface. The outer control panel knob controls the "outer heat zone," which is the outer circle of the cook surface. Because the cook surface is made of heavy steel, it takes 5-8 minutes from a cold start to completely heat the surface. With a pre-heated cook surface, if you adjust one of the burners, you will have to wait momentarily before the heat zone adjusts to temperature. However, if the heat zones are set to different temperatures you can move a pot or pan from one zone to the other and instantly change the cooking temperature beneath your cookware.

### Oiling the Cook Surface

A hand pump spray bottle or a squirt bottle filled with cooking oil is perfect for applying an even, thin coat of oil on the cook surface. Another way to oil the cook surface is with an inexpensive terrycloth cotton towel that has been doused with cooking oil. When the cook surface is hot, hold the oiled towel with a pair of tongs to prevent being burned. Having cooking oil readily available allows you to oil the grill easily and quickly at any time.

### Cooking Meats

Meats are perfect to sear, roast or braise on the grill. Searing and Roasting techniques are described in more detail below. Braising requires a tightly covered pot or pan placed on the grill surface. Braise as you would for a stove-top braising recipe, adjusting the burners to control the cook surface temperature. Meats can also be sliced and put on skewers, added to a stir-fry or used in hot sandwiches. Veal and Pork are often made into cutlets or scallopini. Create small slices that have been lightly flattened with a meat mallet, seasoned and then dusted with flour. Scallopini and cutlets are usually seared in butter until golden brown and served with a sauce or lemon juice and fresh parsley.



## **Cooking Poultry**

Boneless cuts that have been flattened to an even thickness with a meat mallet cook more evenly and more quickly. Poultry that has been prepared in this way can then be marinated, breaded or rubbed with spices before searing on the grill. Poultry can also be roasted, braised, sautéed, fried or poached on the Evo grill. Roast as you would in your kitchen oven placing the roast in a roasting pan with a rack and using the hood to contain the heat from the grill. To sauté, slice the meat into thin strips and sauté, turning with a spatula directly on the cook surface. Use pots and pans for stove-top cooking techniques. Fill a pot with oil for frying or with stock for poaching. Use a tightly covered pot or pan to braise. Small game birds such as quail are small enough that they can be sear cooked all the way through without having to use the hood to create an oven. In the case of duck breast, it is best to sear the skin side of the duck breast first and to continue cooking until the skin becomes crispy and much of the fat has been rendered away. This way the duck meat won't get over cooked before the skin is crispy.

## **Cooking Fish**

Lean fish such as Flounder, Sole, Sea Bass, Cod, Monk Fish and Red Snapper are usually purchased in the form of fillets. Fillets of fish are ideal to cook on the Evo grill because they are flat and will cook quickly and efficiently. Because lean fish tends to flake apart easily, using Evo's flat top grill makes handling and cooking fish much easier than open-flame grills. For additional flavor and texture, you can also lightly dust the seasoned fillets with flour or use a breading mixture before searing. Fatty Fish such as Swordfish, Tuna, Sturgeon, Striped Bass, and Salmon are usually purchased in steaks or fillets. Marinate them, rub them with spices, or simply season with salt and pepper. Sear the fish on a lightly oiled hot cook surface till golden brown and cooked to your desired doneness.

## **Searing**

Sear cooking is the most common cooking technique used on the Evo flat top grill. Searing is done by placing food directly onto the hot cook surface and allowing that food item to develop a flavorful "seared" or browned exterior. Searing imparts flavor to food and also helps seal in natural juices. Searing can be done with vegetables, meats, fish, poultry, etc. One nice feature of the Evo grill is its convex cooking surface. The convex shape allows fats to flow away from your food and into a drip pan. This minimizes flavors from mixing on the cook surface and also helps cut down on fat in your food. Once the food is seared on one side, flip to sear the other side and allow it to finish cooking. Some foods take longer to cook and will require that you reduce the cook surface temperature to finish cooking without over cooking the exterior. With foods that take longer to cook you can also adjust one of the two heat zones to a lower temperature and move food to the lower temperature zone after it has been seared over the high temperature zone. The lower temperature will allow the food to continue cooking while retaining a perfectly browned exterior. For non-stick cooking it is essential that the cook surface be hot and lightly oiled before searing, and that you allow the food to sear before you attempt to move it with your spatula or tongs. Overall, cooking on Evo's flat-top cook surface does not involve the same charring of food that is typically done with an open-flame grill. Cooking with the Evo grill involves a controlled "sear" that develops perfectly browned foods.

## **Using Marinades and Spice Rubs**

When using spice rubs and marinades it is important to be aware of the sugar content in the recipes. If a marinade is high in sugar you will find that when placed on a hot cook surface, the sugars will "caramelize" on the cook surface: similar to what will happen to a pan on your stove top. Caramelized sugars are sticky and will eventually burn off, however to ensure easy cleanup, it's encouraged that you use oil based marinades that are low in sugars. Your cook surface will be easier to clean and you will achieve a better quality sear on your meats, poultry, fish and vegetables.

## **Stir-Fry**

Stir-Fry is best done with very high heat and very quickly, so it's important to keep the food moving throughout the cooking process. Use two spatulas to stir-fry food on the hot cook surface. The two spatula method allows you to scoop the food from both sides at the same time and toss it together. Meats are usually cooked separately from the vegetables and then combined. This allows the meats to brown more efficiently before mixing with the vegetables.

## **Toasting**

Toast bread, croutons, bagels etc. Simply place the item to be toasted directly on the heated grill surface until it is browned. Flip the item over to toast the other side. If you are making breakfast, you can toast bread, bagels or English muffins while directly alongside preparing eggs, bacon, hash browns, and pancakes. No pots or pans are required, and you can cook everything at the same time. You can also toast nuts, seeds, dried peppers and spices on Evo's cook-surface.

## **Smoking**

By placing wood chips such as alder, mesquite or apple wood directly on Evo's hot cook surface and covering the surface with Evo's hood, you can quickly convert your Evo grill into a smoker. Depending on the size of the wood chips, you may want to use the method of placing the chips into a metal container such as folded aluminum foil. At a minimum, make sure the heat zone that comes in contact with the wood chips is hot enough to get the chips smoking. A higher temperature setting produces more smoke and will consume the wood chips more quickly. Once the chips begin to smoke, place the food directly on the cook surface, or for indirect heat, you can use a wire rack to locate foods above the cook surface. Using a wire rack keeps food slightly off the surface allowing smoke and air to circulate. When placing Evo's hood over the food and wood chips you create "hot smoke," since the food is being cooked and smoked simultaneously. Placing the chips onto one heat zone and the food onto the other heat zone allows you to control the smoke and cooking temperature independently. Items that take longer to cook, such as pork ribs, require you add more chips as the old chips burn out. When smoking ribs or other fatty foods, you may want to fashion an aluminum foil pan underneath to speed up the cleaning process. You may also like to try using cedar planks on the cook surface which provides an excellent rich smoke for smoking fish such as salmon.

**Steaming**

The process of steaming on the Evo grill involves applying water directly to the hot cook surface while you are cooking and containing the water as it turns to steam. You can use Evo's hood if you intend to steam everything on the cook surface, or to set up individual steam areas we recommend using a pot cover. As an example, you may want to individually steam vegetables, while simultaneously searing salmon.

**Roasting and Baking**

You can roast meats and vegetables under Evo's hood. Use the front panel control knobs to control roasting temperature. Meats are usually seared on all sides before roasting. Searing creates a nice presentation and adds flavor. When roasting, place the seared meats, fish, poultry or vegetables either on a baking rack placed on the cook surface or directly on the cook surface. We recommend a stainless steel baking rack designed for cooling cookies and cakes. Baking racks are relatively inexpensive and can be found in the cookware department of most supermarkets or kitchen supply stores. A baking rack is useful because it keeps the bottom-side of foods above the cook surface and allows uniform cooking. Placing food directly on the cook-surface works best for smaller cuts of meat or foods that are only roasted for a few minutes.

**Making Flatbreads, Crepes and Tortillas**

Flatbreads, crepes and tortillas are easy to make and are a great accompaniment to many foods. The cook surface is ideal for these items because it provides even heat over the entire surface.

Enjoy Cooking With Evo!



## Care & Use Guide for Gas Grills

### FOR YOUR SAFETY

- 1) Do not store or use gasoline or other flammable vapors and liquids in the vicinity of this or any other appliance.
- 2) An LP cylinder not connected for use shall not be stored in the vicinity of this or any other appliance.

PLEASE READ THIS CARE & USE GUIDE BEFORE USING GRILL.

### To installer or person assembling grill...

Leave this Care & Use Guide with consumer for future reference.

### FOR YOUR SAFETY

If you smell the odor of gas:

- 1) Shut off gas to the grill.
- 2) Extinguish any open flame.
- 3) Remove grill cook surface.
- 4) If odor continues, immediately call your gas supplier or your fire department.

### To Consumer...

Retain this Care & Use Manual for future reference.

**YOUR GRILL IS FOR OUTDOOR USE ONLY**

### Warranty Information

Serial Number: \_\_\_\_\_

Date Purchased: \_\_\_\_\_

## SAFETY PRECAUTIONS

- 1 • Installation of grill must conform with local codes, or in absence of local codes, with **National Fuel Gas Code, NFPA 54 / ANSI Z223.1** - latest edition. **CAN/CGA-B149.2** Propane Installation code latest edition. Handling of LP tanks must conform to **NFPA / ANSI 58** - latest edition.
- 2 • Do not install or use grill within 36" of combustible materials from back and sides of grill. Grill shall not be located under unprotected overhead (enclosed carport, garage, porch, patio) made of combustible construction.
- 3 • Carefully follow directions in the Installation Instructions and Owners Manual and this booklet for proper assembly and gas leak testing of your grill. Do not use grill until leak checked (see page 5). If leak is detected at anytime, it must be stopped and corrected before using grill further.
- 4 • Visually inspect hose before each use of grill. If there is excessive abrasion or wear, or if the hose is cut, it must be replaced prior to grill operation.
- 5 • Only use gas hose included with your Evo grill or specified by Evo.
- 6 • Follow lighting and control instructions as described (on page 7).
- 7 • Very Important: Never attempt to light grill with cook surface removed. Cook surface must be correctly installed for proper operation of grill. Removing cook surface will expose burners with open flame and is very dangerous.
- 8 • Grill area should be kept clear and free from combustible materials, gasoline and other flammable vapors and liquids. Do not obstruct flow of combustion and ventilation air. Keep ventilation openings of LP gas tank enclosure free and clear from debris. Visually check burner flames on regular basis.
- 9 • If you have questions or comments concerning the care and use of your grill, or if you need warranty parts, call Evo Toll-Free at 866-626-1802 or send a Fax to 503-213-5869. To order non-warranty, replacement parts or accessories, call Toll-Free at 866-626-1802 or send or Fax to 503-213-5869.
- 10 • Grill is for outdoor use only. Grill should be operated in a well ventilated space. Never operate in enclosed space, garage or building. Your grill is not intended to be installed in, or on recreational vehicles and/or boats.
- 11 • LP Pressure regulator and hose assembly supplied with grill must be used. Replacement pressure regulators and hose assemblies must be those specified by Evo.
- 12 • Carefully follow instructions in Owners Manual for attaching regulator to LP gas tank.
- 13 • **Warning:** It is the responsibility of the assembler/owner to assemble, install and maintain gas grill. Do not let children operate of play near grill. Failure to follow these instructions could result in serious personal injury and/or property damage.
- 14 • **Purging: Do not release liquid propane (LP) fuel into atmosphere. This is a dangerous practice.** If it is necessary to remove fuel from LP gas tank, please contact nearest LP dealer or call local fire department for assistance.

## LP GAS TANK

- 1 • LP gas tank to be used must measure 12" ( diameter ) x 18" ( tall ) with 20lb. capacity maximum.
- 2 • LP gas tank must be constructed and marked in accordance with specification for LP gas cylinders of the U.S. Department of Transportation (DOT). See tank collar for DOT mark. **National Standard of Canada, CAN/CSA-B339-88.** See tank collar for markings.
- 3 • Carefully follow instructions on page 8, or in your assembly manual for attaching and removing LP gas tank.
- 4 • If grill is not in use, gas must be turned off at LP gas tank.
- 5 • Storage of grill indoors is permissible ONLY if LP gas tank is disconnected, removed from grill and stored outdoors.

**WARNING:** *The combination of an overfilled tank stored under a grill is particularly hazardous due to the possibility of the safety relief valve venting propane under the grill. See safety note 6 and 7 listed below about tank storage and filling.*

- 6 • LP gas tank must be stored outdoors in well-ventilated area out of reach of children. Do not store spare tank under grill frame. LP gas tank must not be stored in building, garage or any other enclosed area.

A disconnected LP gas tank in storage or under transport must have safety cap tightly installed over threaded portion of tank valve (see right). Use retainer strap to permanently attach safety cap to tank valve.

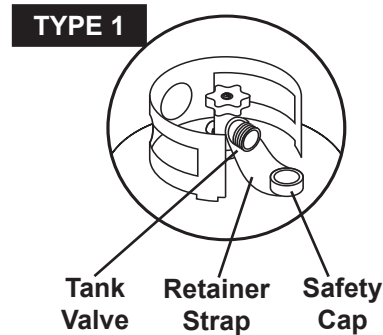

**WARNING:** *Failure to use safety cap as directed may result in serious personal injury and/or property damage.*

- 7 • LP gas tank must have shut off valve terminating in LP gas cylinder valve outlet compatible with connection on grill and conforming to **ANSI Z21.58 / CAN 1.6-88** standards-latest edition.  
LP tank should have approved TYPE 1 valve. LP gas tank must also be provided with safety relief device having direct communication with vapor space of cylinder.  
LP gas tank supply system must be arranged for vapor withdrawal and must include collar to protect tank valve. Also, use propane (LP) gas only.  
Liquefied Petroleum Gas (LP gas) is nontoxic, odorless and colorless when produced. For your safety, LP gas has been given an odor ( similar to rotten cabbage ) so that in the event of a leak, it may be detected easily. Familiarize yourself with its odor.  
Licensed LP dealers must empty air from new LP gas tanks before filling with gas. Check telephone directory under “Gas Company” for the nearest certified LP dealer.

## LEAK TESTING YOUR GRILL

- 1 • **For Your Safety...**
  - a. Do not smoke during leak test.
  - b. Do not use an open flame to check for gas leaks.**
  - c. Always keep LP tank in upright position during use or transport.
  - d. Always use cooking mitt or hot-pad to turn knob on tank.
  - e. A frosty regulator indicates gas overfill. Call local LP gas dealer for assistance.
  - f. Only use pressure regulator supplied with grill. If replacement hose and/or regulator are needed, only Evo part number or cross-referenced number may be used.
  - g. Never remove orifices (gas jets)!
  - h. If you cannot stop gas leak, immediately close tank valve and call LP gas dealer.
  - i. Visually inspect hose before each use of grill. If there is excessive abrasion, cracking or wear, or if the hose is cut, hose must be replaced prior to grill operation. Use hose only as specified by Evo.
  - j. Leak test must be repeated each time tank is refilled, or after storage.** During leak test, keep grill away from open flames or sparks.
- 2 • **Materials required for leak test...**  
Materials include clean paint brush, and 50/50 solution of soap and water.
- 3 • **How to leak test your grill...**
  - a. Grill must be leak checked outdoors in well-ventilated area.
  - b. Be sure control knobs are in off position.
  - c. Completely open tank valve.
  - d. Brush soapy solution onto following connections:  
Tank valve (including threaded parts) into tank, Regulator fittings, Hose and all connections, All tank welds, Valve on gas manifold assembly.
  - e. After completing leak test, close tank valve.
- 4 • **Very Important...**  
If growing bubbles appear, there is a leak! Turn gas off at tank valve immediately. Retighten connections and repeat leak test procedures. Always close tank valve after performing leak test.

## IGNITOR LIGHTING YOUR GRILL

**Notice: For your grill ignitor to function you must first install a battery. Do not attempt to use the ignitor to light the grill burners without first properly installing a functional battery.** Your grill is equipped with an electronic ignitor that requires one AA battery. To install battery, first remove cap containing the red or black rubber button located under the left side of the front control panel by pressing up then twisting. Insert one battery into the ignitor with the positive-side (+) of the battery facing upward. Replace the cap, making sure the button locks into the ignitor. **IMPORTANT: Before checking ignitor, turn gas off at tank and place both control knobs in Off position.** Check to make sure the ignitor is functioning by pressing ignitor button and hold for 2-3 seconds. A “Clicking” should be heard, and a spark should be visible between each collector box and electrode. Be sure to check both collector boxes and both electrodes. Be certain that your battery is clean and operating with a sufficient charge.

- 1 • Be sure cook surface is properly installed and gas control knobs are in the Off position.
- 2 • Turn gas on at tank.
- 3 • Push in and turn either knob on the control panel to the **Lite** position.
- 4 • Press and hold ignitor button (2 or 3 seconds) to light grill. Ignitor button is located under the left front corner of the control panel.  
**Be sure burner lights and stays lit.**
- 5 • After burner lights, adjust knob between **High** or **Low** setting. Repeat for opposite burner.
- 6 • **Warning: If burner(s) do not light, turn both control knobs to the Off position. After waiting 4 minutes, start again.**
- 7 • In wind, or if the ignitor does not work, use match.

**Notice: The control knobs must be in the Off position before turning on the tank valve.** Your grill is equipped with a regulator that detects the loss of back pressure and automatically reduces gas pressure to the control manifold. For the regulator to function properly, the control knobs must be in the OFF position prior to turning on tank valve.

## IGNITOR CHECK

**IMPORTANT:** Turn gas off at tank and place both control knobs in Off position. Press ignitor button and hold for 2-3 seconds. A “Click” should be heard and a spark seen each time between collector box and electrode. Be sure to check both collector boxes and both electrodes. Be certain that your battery is clean and operating with a sufficient charge.

## MATCH LIGHTING YOUR GRILL

- Be sure gas control knobs are in the Off position.
- Be sure grill cook surface is properly installed over burner skirt.
- Turn gas on at tank.
- Place long-stem match into flame viewing portal (see diagram).
- Push in and turn either knob on the control panel to the **Lite** position. **Be sure burner lights and stays lit.**
- After burner lights, adjust knob to **High** or **Low** settings. Push in and turn other knob in order to light opposite burner.
- **Warning: If burner(s) do not light, turn both control knobs to the Off position. After waiting 4 minutes, start again.**

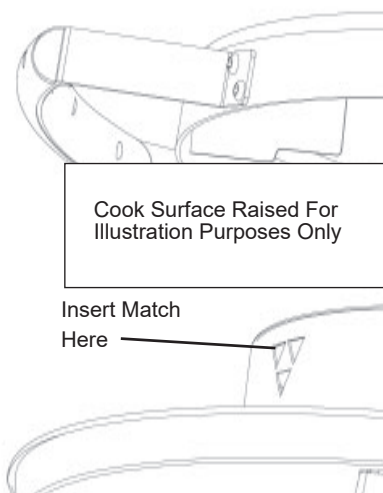

## CHECKING BURNER FLAMES

Light burner using either ignitor or match. Rotate control knobs from **High** to **Low** while viewing flame through the flame portals. You should see a smaller flame in the Low position from that seen in the High position. Always check flame prior to each use.

**Notice:** Flame portals are conveniently located parallel to each three legs and directly below the cooking surface to provide flame monitoring from three positions around grill.

## TURNING YOUR GRILL OFF

To turn grill off, turn both control knobs to off position. Completely close tank valve on LP gas tank (clockwise).

## CHECKING VALVES

**IMPORTANT:** Turn gas off at tank and place both control knobs in Off position.

Both control knobs lock into Off position. To check valves, first push-in knobs and release them. Turn knobs from **Off** to **Low** position. You will notice a slight detent between **Off** and **Low** indicating the **High** position. Knobs should spring back slightly when released. If knobs do not spring back, remove knob from valve stem by pulling outward and checking for obstructions under knob and around valve stem. If no obstruction is found and knob will not spring back, then replace valve before using grill.

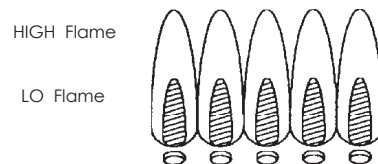

## QUICK GUIDE FOR CLEANING AND CARING FOR EVO GRILL

The exposed surfaces of this grill are made from two types of metal; stainless steel, and a mild grade steel cooking surface.

### Rust on Stainless Steel

Stainless steel is metallurgically incapable of rusting. Any rust that forms is the result of iron particles from an outside source. If you notice rust spots, you can eliminate them with regular cleaning as described above.

### What To Avoid On Stainless Steel

Bleaches containing hypochlorite will cause pitting and staining.  
Silver dip cleaners contain acids that leave a permanent stain.  
Acidic foods, when left for a prolonged time, can cause pitting and staining.  
Examples are citrus fruits, vinegar, mustard, and pickles.

### Cleaning and Maintaining the Cooking Surface

If not properly maintained, the cook surface will accumulate heavy plaque from charred food debris. This issue is easily resolved with routine cleaning between preparations, and gently scraping the cook surface with a metal spatula to remove the majority of surface debris. The cleaning kit contains a professional 3M-brand grill screen handle and pad. Place the pad underneath the grill handle. Use a small amount of vegetable oil on the cook surface and scrub in a circular motion. Take care not to remove the majority of dark seasoning. When finished scrubbing, wipe the surface down with a paper towel or cotton terrycloth. The desired cooking surface should be dark in color, lightly oiled, and smooth.

## BEFORE COOKING ON YOUR GRILL

Your Evo cook surface has been carefully prepared and finished at the factory to provide the best possible cooking surface, however for an

optimum non-stick cooking surface you will first need to 'season' your cooking surface with oil cooked into the steel surface- much like seasoning a cast iron skillet.

## SEASONING AND USING YOUR COOK SURFACE

To provide the non-stick surface preferred for cooking delicate food items, it is necessary to "season" the cook surface with a small amount of vegetable cooking oil. We recommend corn oil because it produces a better seasoned surface than regular vegetable oil. First, lightly coat the entire cooking surface with oil and then warm-up the grill on **High** for 15 minutes. Repeat this process as often as necessary to prevent food from sticking (especially after a heavy cleaning). When cleaning your cooking surface, never remove all of the seasoning, as it's the seasoning that promotes a non-stick surface. A well seasoned cook surface will have a brown to black appearance, and when wiped with a white paper towel will leave only a trace of light brown discoloration.

## CARE OF YOUR COOK SURFACE

Your cook surface is manufactured from a durable steel alloy. With proper care, your cooking surface can provide a lifetime of service.

**To Maintain Cook Surface** - Season often and clean using grill pad, woven nylon or plastic scouring pads (use metal brushes for stubborn residue). We recommend you use the cook surface cleaning kit that came with your Evo grill. Use warm soapy water to clean around grill handles and then wipe dry. The desired cook surface should be dark in color, lightly oiled, and smooth.

**Storage of Cook Surface** - If you are not planning to use your grill for a period of time, it is recommended that the cook surface be cleaned first and then covered and stored in a dry location. If it is not possible to store the grill in a dry area then optionally remove just the cooking surface to a dry area until its next use.

## CLEANING BURNERS and BURNER SKIRT

The grill burners and burner skirt are made completely of stainless steel and require minimal service. Because the burners are not exposed, they will likely require little cleaning. In the event the burners require cleaning use only a damp cloth with warm soapy water. Avoid spraying water directly on burners or allowing water to enter burners through burner ports. To clean the interior and exterior of the burner skirt, use warm soap and water with a soft cloth.

## CARE OF DRIP PAN

The drip pan is made of stainless steel which requires minimal service. To clean the drip pan from food drippings, first wipe with a paper towel toward the drip pan waste container. Remove the stainless steel waste container when full and clean with warm soapy water, or alternatively you can clean the waste container in a dishwasher. Final cleaning of the drip pan should be done with warm soap with water, and a soft cloth.

**Notice:** *Do not use steel wool, woven nylon pads, or abrasive cleaners on the drip pan because they will scratch the surface.*

## CLEANING THE GRILL LID

The grill lid is made of stainless steel with a stainless steel handle, a stainless steel temperature gauge, and stainless steel vent. Care must be taken when cleaning the grill lid as to not damage the glass faced temperature gauge. To clean the grill lid and its components, use warm soap and water with a soft cloth.

## CARE FRAME

The frame is made completely from stainless steel. To clean the stainless steel parts, use warm soap and water with a soft cloth - for tough dirt on stainless steel, use a stronger household liquid cleaner. Wipe dry with a clean cloth.

## STORING YOUR GRILL

Clean the cook surface and drip pan and wipe other grill surface areas clean. Store grill in dry location. When LP tank is connected to grill, store outdoors in well-ventilated area out of the reach of children. Cover grill if stored outdoors.

## REMOVAL AND STORAGE OF LP GAS TANK

Never store LP gas tank indoors. When grill is stored indoors, shut tank valve off and disconnect tank from grill. Tank must be stored outdoors in well-ventilated area, away from and out of the reach of children. Loosen coupling nut located on tank regulator and tank valve by turning counterclockwise using hand only - do not use tools. Next loosen tank securing screws at foot of tank along with frame-assembly cross member and remove tank. Install safety cap over tank valve coupling.

**Figure 1**

**WARNING:** NEVER store tank in enclosed area. Safety relief valve on tank could activate releasing gas and causing a fire. All spare tanks must have safety caps installed in tank outlet. Spare tanks should never be stored near the grill.

## CONNECTING THE REGULATOR TO THE TANK VALVE

Please refer to the diagram in Figure 1 and complete the following steps:

- 1 Be sure both grill burner valves are in the Off position.
- 2 Make sure the gas tank valve hand wheel is in the closed position. Turn clockwise (left to right) to full stop.
- 3 Remove the protective cap from the gas tank valve.
- 4 Hold regulator in one hand and position the plastic coupling nut on the tank valve outlet threads using care to engage the center of the coupling nut to the center of the tank valve outlet. When completing this procedure, take care not to cross-thread the connection.
- 5 Turn the coupling nut clockwise (left to right) and tighten to a full stop.

**Notice:** In the connection process, the regulator will seal on the back-check feature in the tank valve resulting in a slight resistance. The connection requires about one-half to three-quarters additional turn to complete the connection. Tighten by hand only - do not use tools. If you cannot make the connection, disconnect the regulator and repeat steps 4 and 5.

**WARNING:** Do not insert any foreign objects into the valve outlet. You may damage the back-check valve. A damaged back-check module can leak propane. Leaking propane may result in explosion, fire, severe personal injury, or death.

